

Introduction to Euclid Geometry

The necessity of geometry had been felt from ancient times in different parts of the world. The practical problems faced by people of ancient civilization had developed this branch of mathematics. Let us cite few examples.

With floods in the river, the demarcations of land owners on the river-side land were used to wipe out. In order to redraw the boundaries, the idea of area was introduced, the idea of area was introduced. The volumes of granaries could be measured by using geometry. The existence of Egyptian pyramids indicates the use of geometry from olden times. In Vedic period, there was a manual of geometrical construction, known as Sulbasutra's. Different geometrical shapes were constructed as altars to perform various Vedic rites.

The word Geometry originates from the Greek word 'Geo' (earth) and metrein (to measure)

Through Geometry was developed and applied from ancient time in various part the world, it was not presented in a systematic manner. Later in 300 BC, the Egyptian mathematician Euclid, collected all the known work and arranged it in a systematic manner.

'Elements' is a classic treatise in geometry which was written by Euclid. This was the most influential book. The 'element' was used as a text book for several years in western Europe.

The 'elements' started with 28 definitions, five postulates and five common notions and systematically built the rest of plane and solid geometry.

The geometrical approach given by Euclid is known as Euclid method.

The Euclid method consists of making a small set of assumptions and then proving many other proposition from these assumptions.

The assumptions, made were obvious universal truth. The two types of assumption, made were 'axioms' and 'postulates'.

Euclid's Definitions

Euclid listed 23 definitions in book 1 of the 'elements'. We list a few of them:

- 1) A point is that which has no part
- 2) A line is a breadth less length
- 3) The ends of a line are points
- 4) A straight line is a line which lies evenly with the points on itself.
- 5) A surface is that which has length and breadth only.
- 6) The edges of a surface are lines
- 7) A plane surface is surface which lies evenly with straight lines on its self.

Starting with these definitions, Euclid assumed certain assumptions, known as axioms and postulates.

Euclid's Axioms

Axioms were assumptions which were used throughout mathematics and are not specifically linked to geometry. Few of Euclid's axioms are

- 1) Things which are equal to the same thing are equal to one another.
- 2) If equals are added to equals; the wholes are equal.

- 3) If equals are subtracted from equals, the remainders are equal.
- 4) Things which coincide one another are equal to one another.
- 5) The whole is greater than the part
- 6) Things which are double of the same thing are equal to one another.
- 7) Things which are half of the same things are equal to one another.

All these axioms refer to magnitude of same kind.

Axiom - 1 can be written as follows:

If $x = Z$ and $y = Z$, then $x = y$

Axiom - 2 explains the following:

If $x = y$, then $x + Z = y + Z$

According to axiom - 3,

If $x = y$, then $x - Z = y - Z$

Axiom - 4 justifies the principle of superposition that every thing equals itself.

Axiom - 5, gives us the concept of comparison.

If x is a part of y , then there is a quantity Z such that $x = y + Z$ or $x > y$

Note that magnitudes of the same kind can be added, subtracted or compared.

Euclid's Postulates

Euclid used the term postulate for the assumptions that were specific to geometry.

Euclid's five postulates are as follows:

Postulate 1: A straight line may be drawn from any one point to any other point.

Same may be stated as axiom 5.1

Given two distinct points, there is a unique line that passes through them.

Postulate 2: A terminated line can be produced indefinitely.

Postulate 3: A circle can be drawn with any centre and any radius.

Postulate 4: All right angles are equal to one another.

Postulate 5: If a straight line falling on two straight lines makes the interior angle on the same side of it taken together less than two right angles, then two straight lines, if produced indefinitely, meet on that side on which the sum of the angles is less than two right angles.

Postulates 1 to Postulates 4 are very simple and obvious and therefore they are taken a 'self evident truths'. Postulates 5 is complex and it needs to be discussed.

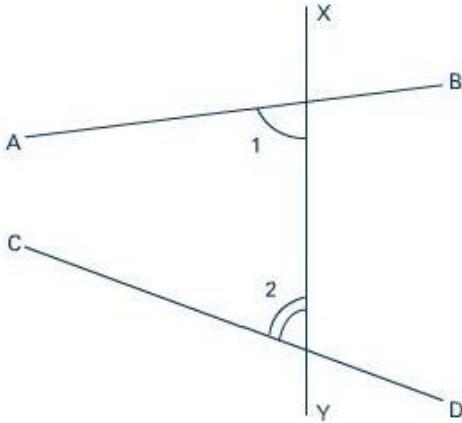

Suppose the line XY falls on two lines AB and CD such that $\angle 1 + \angle 2 < 180^\circ$, then the lines AB and CD will intersect at a point. In the given figure, they intersect on left side of PQ, if both are produced.

Note:

In mathematics the words axiom and postulate may be used interchangeably, though they have distinct meaning according to Euclid.

System of Consistent Axioms

A system of axioms is said to be consistent, if it is impossible to deduce a statement from these axioms, which contradicts any of the given axioms or proposition.

Proposition or Theorem

The statement or results which were proved by using Euclid's axioms and postulates are called propositions or Theorems.

Theorem:

Two distinct lines cannot have more than one point in common.

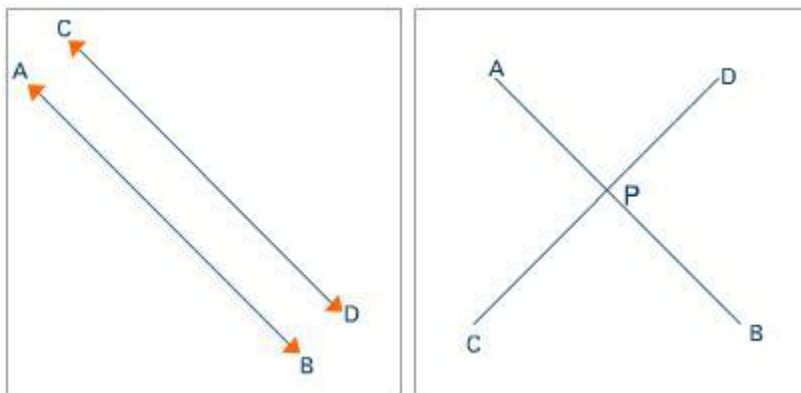

Proof:

Given: AB and CD are two lines.

To prove:

They intersect at one point or they do not intersect.

Proof:

Suppose the lines AB and CD intersect at two points P and Q.

This implies the line AB passes through the points P and Q.

Also the line CD passes through the points P and Q.

This implies there are two lines which pass through two distinct point P and Q. But we know that one and only one line can pass through two distinct points. This axiom contradicts out assumption that two distinct lines can have more than one point in common.

The lines AB and CD cannot pass through two distinct point P and Q.

Equivalent Versions of Euclid's Fifth Postulate

The two different version of fifth postulate

- a) For every line l and for every point P not lying on l , there exist a unique line m passing through P and parallel to l .

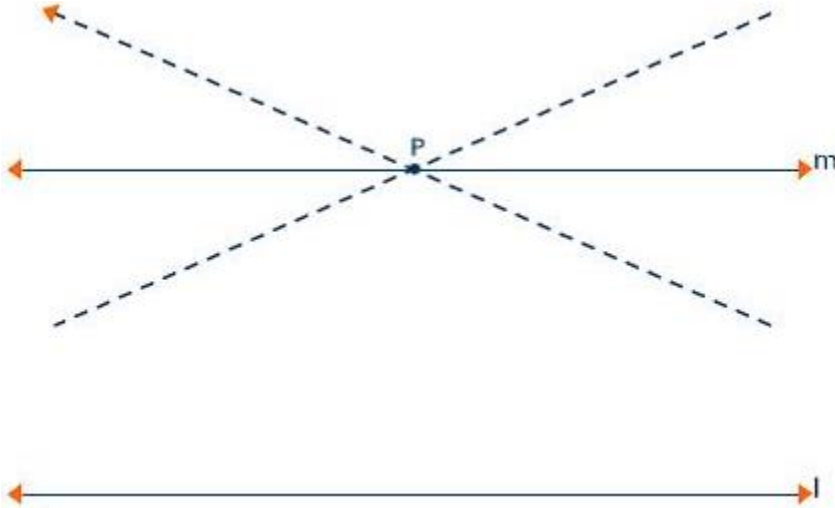

- b) Two distinct intersecting lines cannot be parallel to the same line.